



# Balluff Catalog on PARTcommunity with product selectors

## Balluff GmbH. sensor solutions and systems.

With over 50 years of sensor experience, Balluff GmbH is a world leader and one of the most efficient manufacturers of sensor technology.





# Balluff Catalog on PARTcommunity with product selectors

**BALLUFF**  
*sensors worldwide*

## Balluff GmbH. German location

Balluff is a medium-sized family business in the fourth generation.

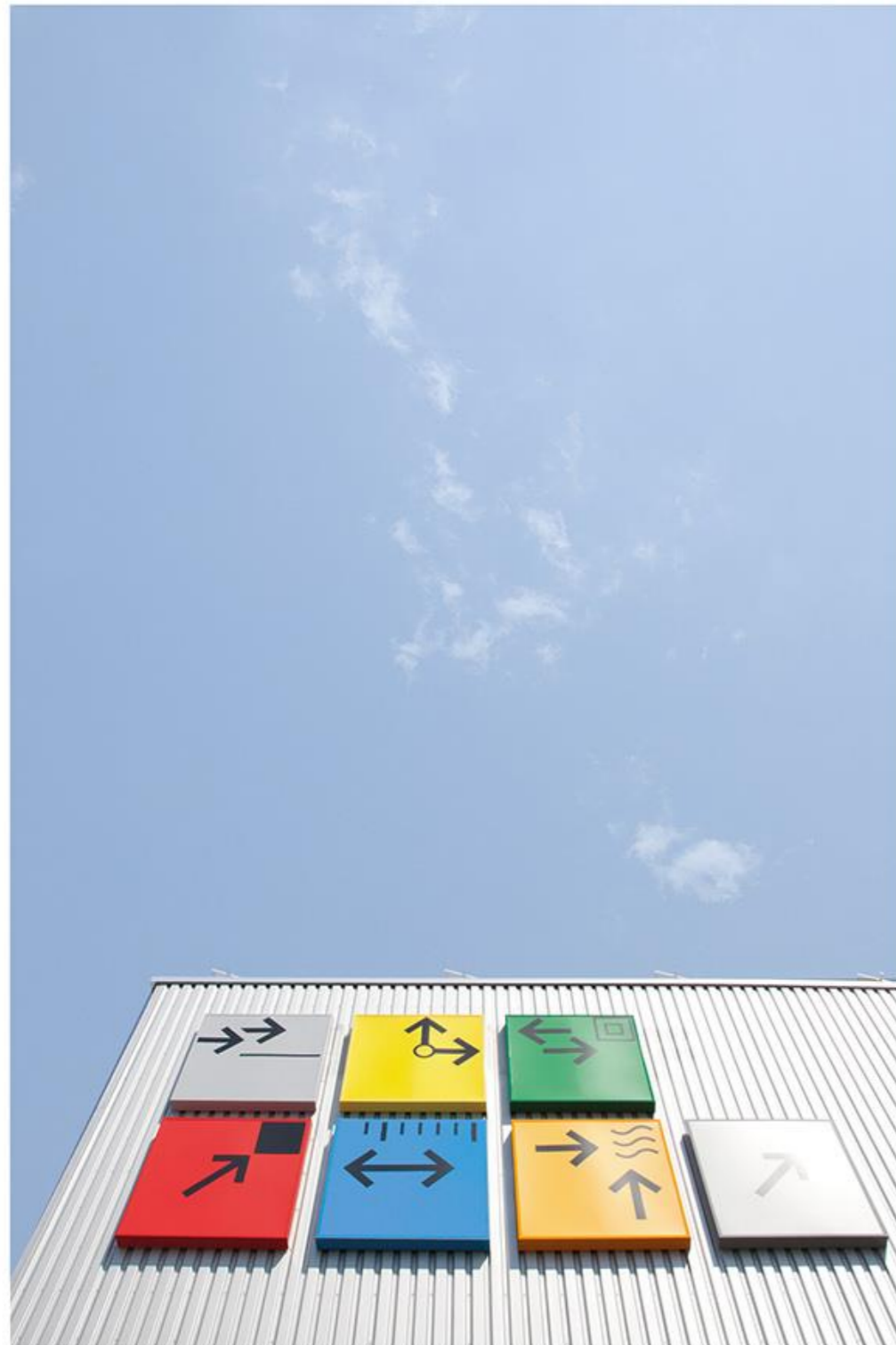



# Balluff Catalog on PARTcommunity with product selectors

## Global presence

At 56 subsidiaries/representatives

8 production sites

2600 employees



### Europa

- |                    |                           |                      |           |           |
|--------------------|---------------------------|----------------------|-----------|-----------|
| Deutschland (Head) | Österreich                | Belarus              | Belgien   | Bulgarien |
| Kroatien           | Tschechische Republik     | Dänemark             | Estland   | Finnland  |
| Frankreich         | Großbritannien und Irland | Griechenland         | Ungarn    | Island    |
| Italien            | Kasachstan                | Lettland             | Litauen   | Luxemburg |
| Niederlande        | Norwegen                  | Polen                | Portugal  | Rumänien  |
| Russland           | Serbien                   | Slowakische Republik | Slowenien | Spanien   |
| Schweden           | Schweiz                   | Türkei               | Ukraine   |           |

### Nord- und Südamerika

- |           |             |           |        |       |
|-----------|-------------|-----------|--------|-------|
| USA       | Argentinien | Brasilien | Kanada | Chile |
| Kolumbien | Mexiko      | Venezuela |        |       |

### Asien und Pazifik

- |               |          |             |          |            |
|---------------|----------|-------------|----------|------------|
| Australien    | China    | Hongkong    | Indien   | Indonesien |
| Japan         | Malaysia | Philippinen | Singapur | Korea      |
| Taiwan R.O.C. | Thailand | Vietnam     |          |            |

### Afrika und Naher Osten

- |         |               |           |                              |      |
|---------|---------------|-----------|------------------------------|------|
| Bahrain | Ägypten       | Israel    | Kuwait                       | Oman |
| Katar   | Saudi-Arabien | Südafrika | Vereinigte Arabische Emirate |      |



# Balluff Catalog on PARTcommunity with product selectors

## Balluff GmbH. Global Player

Balluff HyTech  
Biel, Switzerland



R+D, Fertigung

Balluff SIE Sensorik,  
Viernheim, Germany



R+D, Fertigung

Balluff GmbH,  
Neuhausen, Germany



R+D Zentrum, Fertigung

Balluff High Resolution  
Kirchheim, Germany



R+D, Fertigung

Balluff KFT  
Veszprém, Hungary



R+D, Fertigung

Balluff Inc.  
Florence, USA



R+D, Fertigung



Balluff Controles  
Vinhedo, Brazil  
R+D, Fertigung

Balluff Sensors  
Chengdu, China



R+D, Fertigung

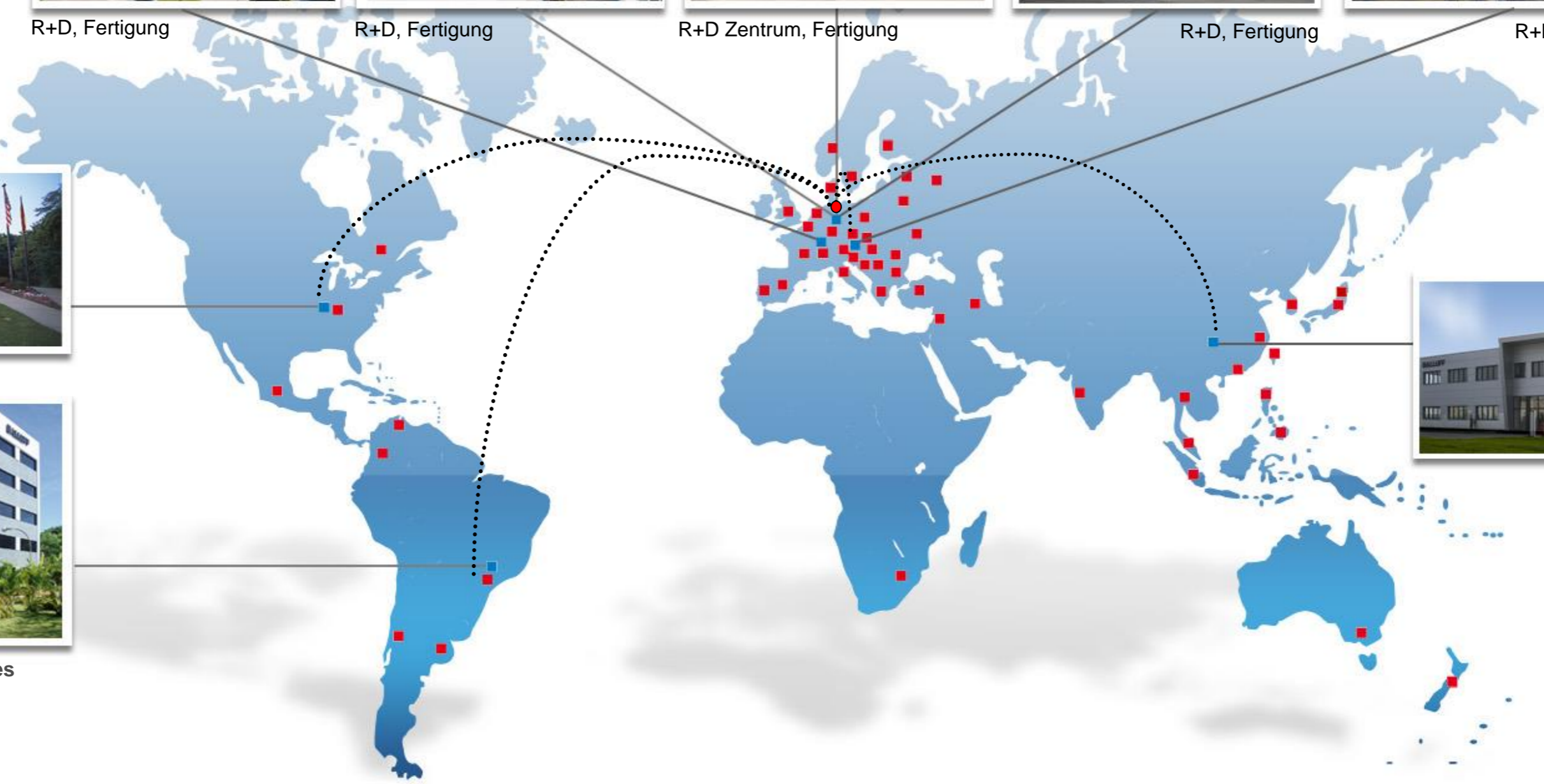



# Balluff Catalog on PARTcommunity with product selectors

**BALLUFF**  
*sensors worldwide*

**Balluff GmbH.** At home in many fields





## Balluff. Full Range

Systems and Services

Industrial Networking and Connectivity

Industrial Identification

Object Detection

Linear Position and Distance Measurement

Condition Monitoring and Fluid Sensors

Accessories

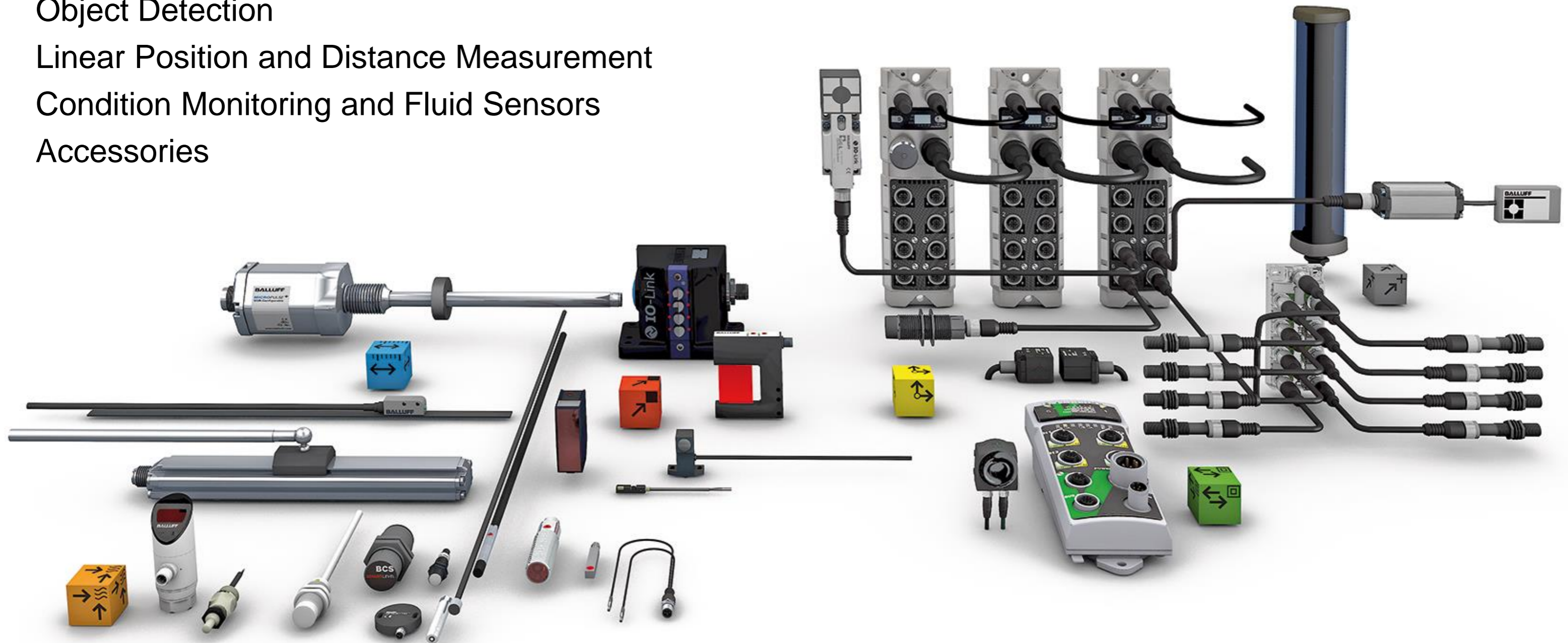



## Balluff. For all areas of automation

- Object detecting sensors
- The latest linear position measurement technology
- Newest identification procedures
- Fluid sensors
- Networking and connector technology for industrial communication
- Tailored systems and individual solutions
- Comprehensive services
- Comprehensive accessories

Balluff masters the entire technological spectrum with all operating principles and offers a comprehensive program of the best networking and connector technology.

Tailored systems and comprehensive services guarantee individual and highly economical applications.



## Balluff Catalog on PARTcommunity. Figures and facts

Currently about 90 % of the Balluff products are listed as 3D models on PARTcommunity. Trend: rising.

Number of models is rising in 2013 to more than 10 000.

Erstellung 3D Modelle für den Balluff Katalog







## Balluff Catalog on PARTcommunity. Facts and figures

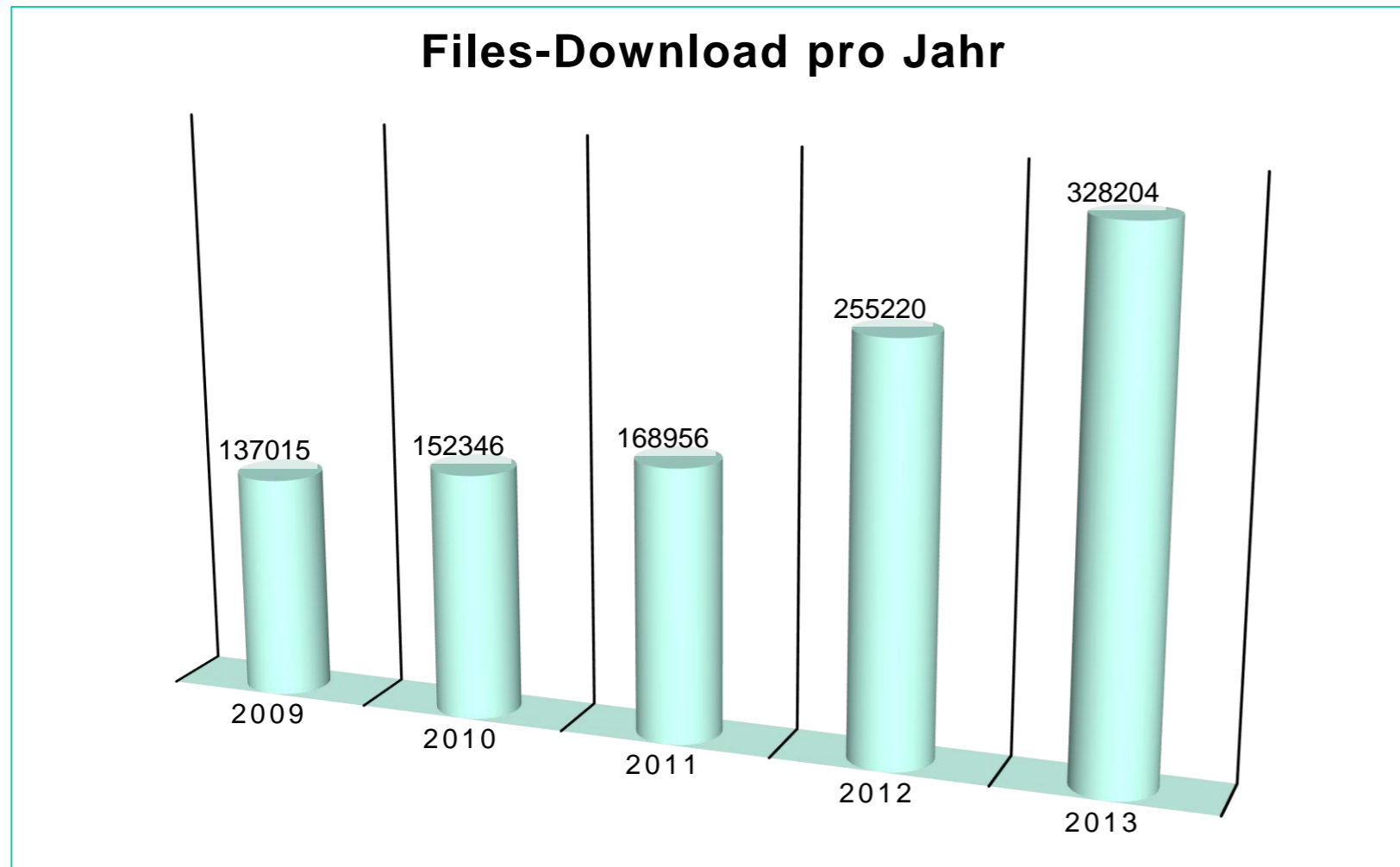

Continuous growth of downloads.

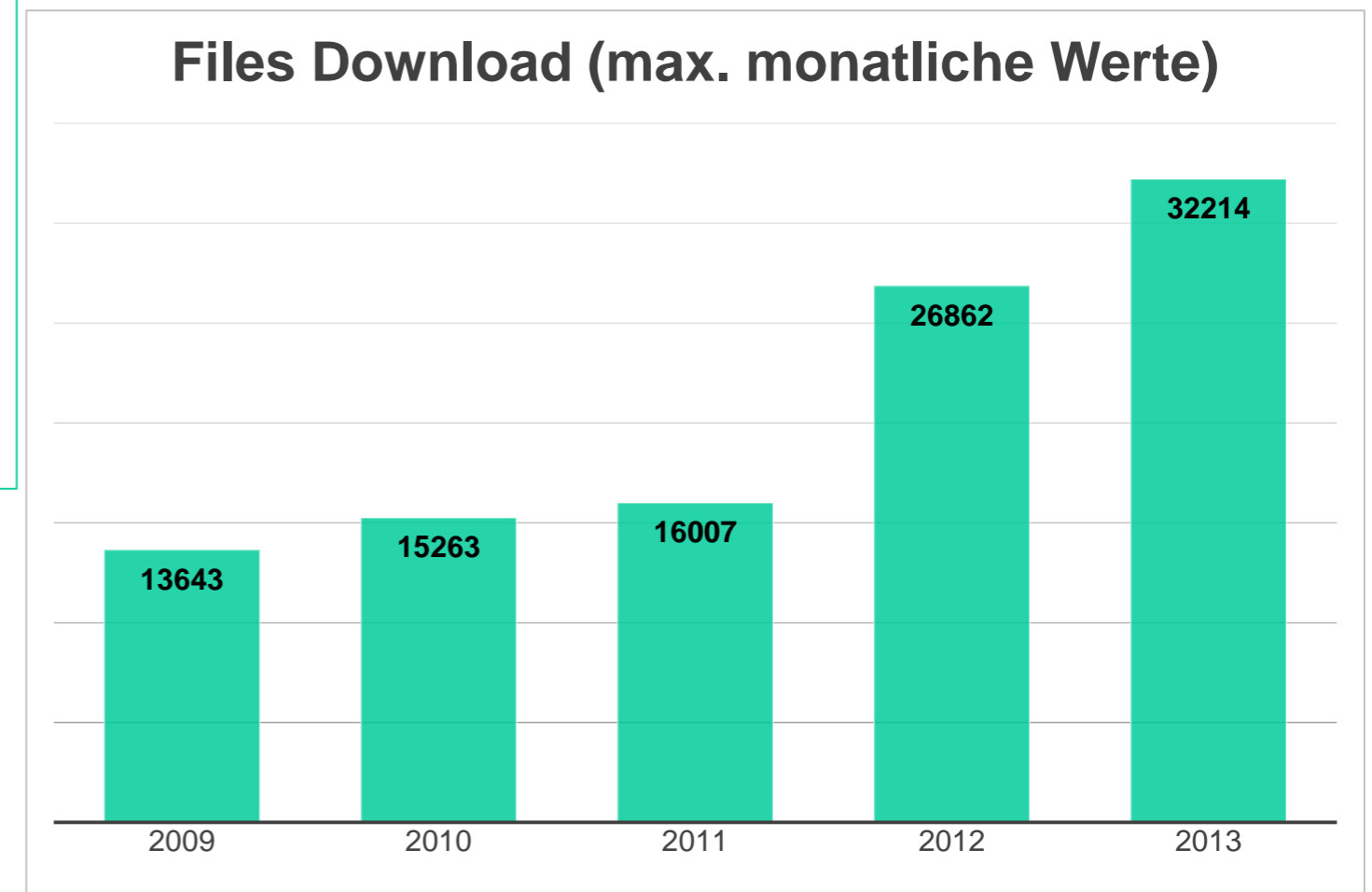

With such a high number of visitors the catalog should offer the possibility to find the product by searching for it as well as by means of the multi variable selection.



## Product search.

For our comprehensive catalog the fast and precise search is of highest priority and customers who know the order code or article description will reach their target with only a few clicks.

Search for variables with the „order code“ and „article description“.

Suchkriterien			
Name	Beschreibung	Vergleich	Wert
BC	Bestellcode	= ▾	<input type="text"/>
BG	Baugroesse	= ▾	<input type="text"/> mm
AB	Artikelbezeichnung	= ▾	BES M12MI-PSC20B-S04G

The exact defined search for the “article description“ delivers a precise result:

	1		BALLUFF BES M12MI- PSC20B- S04G	BES0060	BES M12MI-PSC20B-S04G	Induktiver Näherungsschalter	40949_00	PNP	Schließer	M
--	---	--	--	---------	-----------------------	---------------------------------	----------	-----	-----------	---

**Aktionen**

Schritt 1: [Generiere Vorschau](#) (optional, falls benötigt)

Schritt 2: [Generiere CAD MODELL](#) oder [Generiere PDF-Datenblatt](#)

Schritt 3: [Download bereits generierter CAD MODELLE](#)



## Product selection without product selector.

It's a different situation, if the customer has specific ideas about the product, but knows neither the order code nor the article description. For instance: wire inductive sensors 3-4 M12, PNP, Normally open, wire, flush, pressure rated up to 20 bars.

**BALLUFF**  
sensors worldwide



















Willkommen | CAD Modelle

Anmelden  
Zugang erstellen  
Aktivieren  
Aktivierungsmail  
Passwort?  
Feedback

**Modellauswahl**

Navigation Allgemein  
Zurück Startseite Sprache

Produkt Gruppen

 Ultraschall Sensoren 22.07.2013	 Induktive Sensoren 09.09.2013	 Optoelektronische Se 09.09.2013	 Magnetfeld-Sensoren 14.06.2013
 Kapazitive Sensoren 25.04.2013	 Micropulse Wegaufne 05.09.2013	 Magnetband-Längenr BML 05.06.2013	 Elektromechanische S 06.09.2013
 Identifikations-System 16.08.2013	 Magneto-induktive We BIL 20.11.2012	 Zubehoer 19.08.2013	 Connectivity 29.08.2013
 Fluidsensorik 09.09.2013	 Induktive Koppler BIC 29.08.2013	 Induktives Positionier 09.09.2013	 Induktive Abstandsse 20.02.2013
 Neigungssensoren BS 28.02.2013	 Copyright copyright 31.01.2012		



## Product selection without product selector.

At this point the first difficulties arise: the desired sensor fits the category 3-4 wire, but at the same time – through the criterion “pressure rated” – it fits the folder “sensors with special properties”.

**BALLUFF**  
sensors worldwide

Willkommen | CAD Modelle

Anmelden  
Zugang erstellen  
Aktivieren  
Aktivierungsmail  
Passwort?  
Feedback

**Modellauswahl**

Balluff > Induktive Sensoren

Navigation Allgemein  
Zurück Startseite Sprache

**Produkt Gruppen**

Produkt Gruppe	Datum
DC 3-4 Draht	14.08.2013
DC-2 Draht	17.12.2012
AC DC	04.12.2012
Sensoren mit besond Eigenschaften	09.09.2013
AC-2 Draht	23.07.2012



# Balluff Catalog on PARTcommunity with product selectors

Product selection without product selector.  
Content of the folder "sensors with special properties".

The screenshot displays the Balluff website interface. On the left, there is a navigation menu with options like 'Anmelden', 'Zugang erstellen', 'Aktivieren', 'Aktivierungsmail', 'Passwort?', and 'Feedback'. The main content area is titled 'Modellauswahl' and shows a grid of product cards. Each card includes a small image of the sensor, a title (e.g., 'BES M5 x 0.5 Sensoren besonderen Eigensch'), and a date. One card, 'BES M12 x 1 Sensoren besonderen Eigensch', is highlighted with a red border. To the right of the grid is a search sidebar with 'Suchkriterien' (Search criteria) and a search input field. Below the search sidebar is a '3D Vorschau für CAD MODELLE' (3D preview for CAD models) window, which is currently empty. The bottom right corner of the page shows the Google logo.









## Product selection without product selector. Table “M12 sensors with special properties“.

Optional: [? Angebotsanfrage](#)

CAD Modelle

Ausblenden unter%:   (70 %) [Geometrische Suche](#)

« « 1 2 3 4 5 **6** » »

		BP00,2-S04-004								
<input type="radio"/>	128		BALLUFF BES 516-300-S333-D-PU-00,1	BHS0070	BES 516-300-S333-D-PU-00,1	Induktiver Näherungsschalter	44847_01	PNP	Schließer	M
<input type="radio"/>	129		BALLUFF BES 516-300-S335-S4-D	BES03PP	BES 516-300-S335-S4-D	Induktiver Näherungsschalter	45314_00	PNP	Schließer	M
<input type="radio"/>	130		BALLUFF BES 516-300-S336-D-SP-01	BHS0074	BES 516-300-S336-D-SP-01	Induktiver Näherungsschalter	45591_00	PNP	Schließer	M
<input type="radio"/>	131		BALLUFF BES M12MG-PSC40A-S04G-W	BES03YR	BES M12MG-PSC40A-S04G-W	Induktiver Näherungsschalter	45690_00	PNP	Schließer	M
<input type="radio"/>	132		BALLUFF BES 516-300-S205-D-S4-00,3	BHS007E	BES 516-300-S205-D-S4-00,3	Induktiver Näherungsschalter	46973_00	PNP	Schließer	M
<input type="radio"/>	133		BALLUFF BES 516-325-SA72	BES0451	BES 516-325-SA72	Induktiver Näherungsschalter	47158_00	PNP	Schließer	M
<input type="radio"/>	134		BALLUFF BES 516-300-S342-S4-N	BHS007K	BES 516-300-S342-S4-N	Induktiver Näherungsschalter	48057_00	NAMUR (analog)		M

« « 1 2 3 4 5 **6** » »

- Schritt 1: [Generiere Vorschau](#) (optional, falls benötigt)
- Schritt 2: [Generiere CAD MODELL](#) [Generiere PDF-Datenblatt](#)
- Schritt 3: [Download bereits generierter CAD MODELLE](#)
- Optional: [? Angebotsanfrage](#)

CAD Modelle

Ausblenden unter%:   (70 %) [Geometrische Suche](#)

« « 1 2 3 4 5 **6** » »

alter	44847_01	PNP	Schließer	M12x1 x 47	bündig	öldruckfest bis 500 bar	1,5 mm
alter	45314_00	PNP	Schließer	M12x1	bündig einbaubar	-	1,5 mm
alter	45591_00	PNP	Schließer	M12x1	bündig	-	1,5 mm
alter	45690_00	PNP	Schließer	M12x1	bündig	-	4 mm
alter	46973_00	PNP	Schließer	M12x1	bündig einbaubar	öldruckfest bis 350 bar	1,5 mm
alter	47158_00	PNP	Schließer	M12x1	bündig einbaubar	druckfest bis 20 bar	2 mm
alter	48057_00	NAMUR (analog)		M12x1 x 56	bündig	öldruckfest bis 500 bar	1,5 mm

« « 1 2 3 4 5 **6** » »



# Balluff Catalog on PARTcommunity with product selectors

**Product selection without product selector.**  
Content of the folder “DC 3-4 wire“.

**Modellauswahl**

Balluff > Induktive Sensoren > DC 3-4 Draht

**Navigation** Allgemein

Zurück Startseite Sprache

**Produkt Gruppen**

BES M5 x 0.5 25.10.2012	BES M8 x 1 05.06.2013	BES M12 x 1 18.12.2012	BES M18 x 1 23.11.2012
BES M30 x 1.5 04.12.2012	BES 3 mm 25.10.2012	BES 4 mm 25.10.2012	1351 25.10.2012
BES 8 mm 25.10.2012	BES 5 x 5 25.10.2012	BES 16.5 x 30 x 10.5 25.10.2012	1352 25.10.2012
BES 26 x 40 25.10.2012	BES 25 x 50 25.10.2012	BES 42 x 22 25.10.2012	1353 25.10.2012
BES Doppelsensor 25.10.2012	BES 40 x 40 Unisensor 25.10.2012	BES 80 x 80 Maxisensor 25.10.2012	1354 25.10.2012
BES fuer T-Nut 20.03.2013	Induktive Schlauchsen 25.10.2012	BES 8 x 8 10.05.2013	1355 25.10.2012
BES D11 25.10.2012	BES 20 mm 25.10.2012	BES 26x26 25.10.2012	1356 25.10.2012
Sonderbauformen	BES D18 - Balluf - Induk	BES 17.5 x 17.3	1357 25.10.2012

	BALLUFF BES M18ME-PSC50B-S04G-003(0)	M18	Steckverbinder	PNP	Schließer (NO)	bündig	5,00 mm
	BALLUFF BES M18ME-POC80B-S04G-003(0)	M18	Steckverbinder	PNP	Öffner (NC)	bündig	8,00 mm
	BALLUFF BES M18ME-NSC80B-S04G-003(0)	M18	Steckverbinder	NPN	Schließer (NO)	bündig	8,00 mm
	BALLUFF BES 516-326-G-BO-C-PU-05(0)	M18	Kabel	PNP	Schließer (NO)	bündig	8,00 mm
	BALLUFF BES 516-326-G-BO-C-PU-03(0)	M18	Kabel	PNP	Schließer (NO)	bündig	8,00 mm
	BALLUFF BES 516-326-G-BO-C-PU-02(0)	M18	Kabel	PNP	Schließer (NO)	bündig	8,00 mm
	BALLUFF BES 516-326-G-S4-H(0)	M18	Steckverbinder	PNP	Schließer (NO)	bündig	8,00 mm



# Flash animation „Explaining the selector principle“







# Balluff Catalog on PARTcommunity with product selectors

## Product selection with product selector.

We implemented this principle in cooperation with the CADENAS specialists and I would like to introduce the results to you.

First the complete catalog had to be reconstructed.

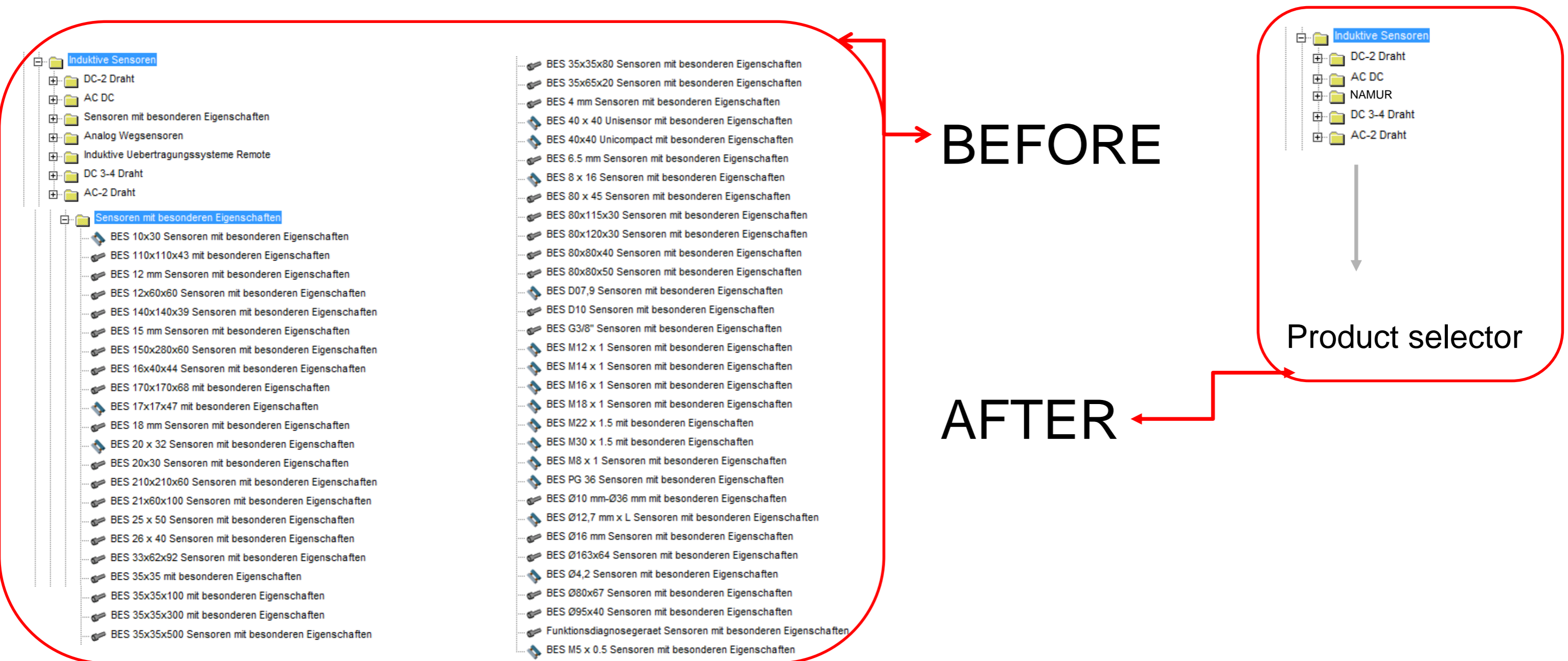



# Balluff Catalog on PARTcommunity with product selectors

## Product selection with product selector.

Regarding the selection criteria of the Balluff Homepage:

Customers, who already know the Balluff website should be able to work with the CADENAS catalog without difficulties or adaptations.

Available products: 1799

Name	Description	Value
BA	Series	M8
AN	Connection	Cable
SAU	Switching output	PNP
	Snap switches function	Open (NO)
	Mounting	flush
	Rated operating distance	1,50 mm
	Housing material	Stainless steel
	Housing Size	M08x1x45,0 mm
	Special properties	
	Trade name	
	Order code	BES01AA
	Product identifier	BES 516-324-EO-C-10
	PX-Number	41222_00
	Tech. Details	<a href="#">Tech. Details</a>
L1		0.0 Zoll
		41222_00.bmp

**Produktselektor induktive Sensoren**

**Baureihe** auswählen: Ø 3, Ø 4, M5, Ø 6,5, Ø 8, M8, Ø 10e7, Ø 10,5

**Anschlussart** auswählen: Kabel, Kabel mit Steckverbinder, Litzenanschluss, Schraubklemme, Steckverbinder

**Ausgang** auswählen: PNP, NPN, DC 2-Draht, AC/DC 2-Draht, AC 2-Draht, NAMUR

**Schaltfunktion** auswählen: Schließer, Öffner, antivalent

**Mechanische Einbaubedingung** auswählen: bündig, einseitig bündig, nichtbündig, quasibündig

**Reichweite** auswählen: bis 2mm, bis 4 mm, bis 6 mm, bis 8 mm, bis 10 mm, bis 15 mm, bis 30 mm

**Gehäusewerkstoff** auswählen: Edelstahl, rostfrei, Kunststoff, Metall

**Besondere Eigenschaften** auswählen: kleine Bauform, beständig gegen Hochdruckreiniger, Diagnosefunktion, Ex-geschützt, große Reichweite, hochdruckfest

**Handelsname** auswählen: Bunkerprox, Desina, Faktor 1, Global, Proxinox®, Steelface, High-End



## Product selection with product selector.

On the PARTcommunity portal we placed a little note to make the handling of the catalog easier for our customers:



**BALLUFF**  
sensors worldwide

Willkommen | CAD Modelle

**Hinweis**

Für die schnelle Suche geben Sie bitte den Bestellcode oder die Bezeichnung in die Suchfelder rechts ein.

Im unteren Produktbereich können Sie das gewünschte Produkt nach technischen Kriterien selektieren. Klicken Sie auf den gewünschten Produktordner bis die Tabelle erscheint. Die blau markierten Tabellenwerte sind Zeichen für die Selektionsmöglichkeit.

**Modellauswahl**

Balluff

**Navigation**      **Allgemein**

← Zurück    Home    Sprache

**Produkt Gruppen**

- [Ultraschall Sensoren](#)
- [Induktive Sensoren](#)
- [Optoelektronische Se](#)
- [Magnetfeld-Sens](#)



## Product selection with product selector.

Further proceeding on the example of wire inductive sensors 3-4 M12, PNP, normally open, wire, flush, pressure rated up to 20 bars:

**Hinweis**

Für die schnelle Suche geben Sie bitte den Bestellcode oder die Bezeichnung in die Suchfelder rechts ein.

Im unteren Produktbereich können Sie das gewünschte Produkt nach technischen Kriterien selektieren. Klicken Sie auf den gewünschten Produktordner bis die Tabelle erscheint. Die blau markierten Tabellenwerte sind Zeichen für die Selektionsmöglichkeiten.



**Modellauswahl**

Balluff

**Navigation** Allgemein

Zurück Home Sprache

**Produkt Gruppen**

 Ultraschall Sensoren 25.11.2013	 Induktive Sensoren 25.11.2013	 Optoelektronische Se 27.11.2013	 Magnetfeld-Sensoren 23.11.2013
 Kapazitive Sensoren 23.11.2013	 Micropulse Wegaufne 27.11.2013	 Magnetband-Längenr BML 27.11.2013	 Elektromechanische S 27.11.2013
 Identifikations-System 05.12.2013	 Magneto-induktive We BIL 24.11.2013	 Zubehoer 02.12.2013	 Connectivity 04.12.2013
 Fluidsensorik 23.11.2013	 Induktive Koppler BIC 23.11.2013	 Induktives Positionier 23.11.2013	 Induktive Abstandsse 23.11.2013

**Hinweis**

Für die schnelle Suche geben Sie bitte den Bestellcode oder die Bezeichnung in die Suchfelder rechts ein.

Im unteren Produktbereich können Sie das gewünschte Produkt nach technischen Kriterien selektieren. Klicken Sie auf den gewünschten Produktordner bis die Tabelle erscheint. Die blau markierten Tabellenwerte sind Zeichen für die Selektionsmöglichkeiten.





**Modellauswahl**

Balluff Induktive Sensoren

**Navigation** Allgemein

Zurück Home Sprache

**Produkt Gruppen**

 DC 3-4 Draht 25.11.2013	 DC-2 Draht 25.11.2013	 AC DC 23.11.2013	 NAMUR 25.11.2013
 AC-2 Draht 23.11.2013			



## Product selection with product selector.

Please select the desired product according to technical criteria. Selectable attributes are highlighted with the table icon. Selections can be reset by clicking on the table icon or on the value.

Available products: 1799

Name	Description		Value
BA	Series		M8
AN	Connection		Cable
SAU	Switching output		PNP
SEL	Snap switches function		Open (NO)
EIN	Mounting		flush
BSA	Rated operating distance		1,50 mm
WG	Housing material		Stainless steel
BG	Housing Size		M08x1x45,0 mm
BE	Special properties		
HN	Trade name		
BC	Order code		BES01AA
AB	Product identifier		BES 516-324-EO-C-10
PX	PX-Number		41222_00
TECH	Tech. Details		<a href="#">Tech. Details</a>
L1	L1		0.0 Zoll
ICON	ICON		41222_00.bmp 

Search text:

CAD model 3D preview

Actions

This is a pregenerated default preview. It may differ from your current selection.

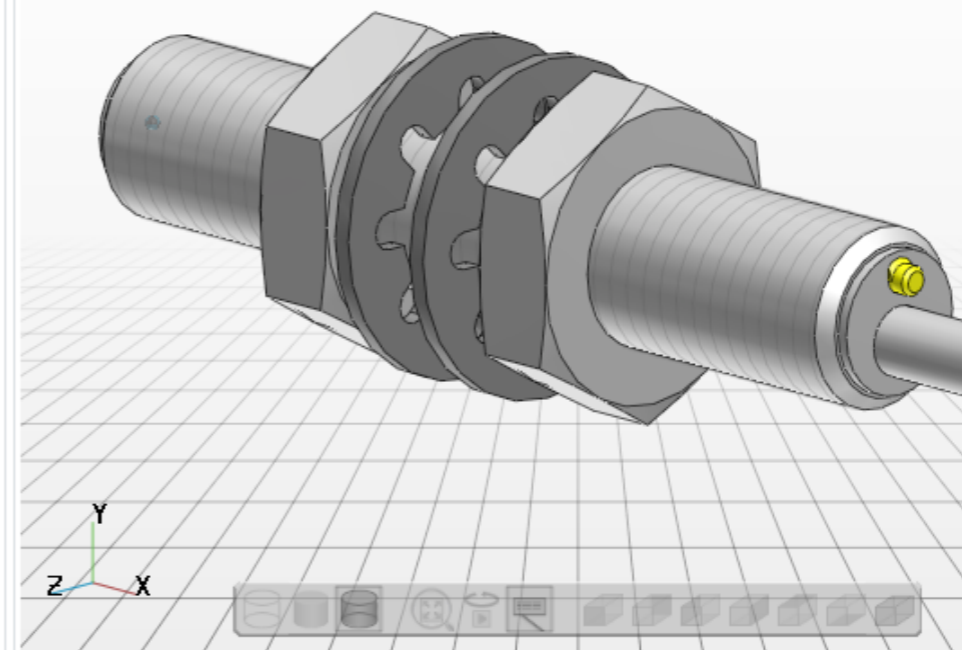

Download CAD models

Actions

[Edit CAD formats](#)

Available CAD models



# Balluff Catalog on PARTcommunity with product selectors

## Product selection with product selector.

Selection „size M12": now only 333 products are displayed.

Please select the desired product according to technical criteria. Selectable attributes are highlighted with the table icon. Selections can be reset by clicking on the table icon or on the value.

Available products: 333 [Remove all filters](#)

Name	Description	Value
BA	Series	M8
AN	Connection	Cable
SAU	Switching output	PNP
SEL	Snap switches function	
EIN	Mounting	
BSA	Rated operating distance	
WG	Housing material	
BG	Housing Size	
BE	Special properties	
HN	Trade name	
BC	Order code	
AB	Product identifier	
PX	PX-Number	
TECH	Tech. Details	
L1	L1	
ICON	ICON	

**Filter settings**

General information

Column name: BA  
Description: Series  
Unit:

Filter definition

- IKU
- M05
- M08
- M12**
- M14
- M16
- M18
- M22

Name	Description	Value
	Series	M12
	Connection	Connector
	Switching output	NPN
	Snap switches function	normally-closed (NC)
	Mounting	flush
	Rated operating distance	2,00 mm
	Housing material	CuZn
	Housing Size	M12x1x65,0 mm
	Special properties	
	Trade name	Global
	Order code	BES004Y
	Product identifier	BES M12MI-NOC20B-S04G
	PX-Number	40949_00
	Tech. Details	<a href="#">Tech. Details</a>
	L1	0.0 Zoll
	ICON	40949_00.bmp 



## Product selection with product selector.

Further selection: „Output PNP“

(248 products) and

















„special properties – pressure rated

Up to 20 bars“: there’s already the result

- one explicit product.

 Please select the desired product according to technical criteria. Selectable attributes are highlighted with the table icon. Selections can be reset by clicking on the table icon or on the value.

Available products: 1  Remove all filters

Name	Description		Value
BA	Series		M12
AN	Connection		Connector
SAU	Switching output		PNP
SEL	Snap switches function		normally-open
EIN	Mounting		flush
BSA	Rated operating distance		2,00 mm
WG	Housing material		CuZn
BG	Housing Size		M12x1x31,0 mm
BE	Special properties		Pressure-rated up to 20 bar
HN	Trade name		
BC	Order code		BES0451
AB	Product identifier		BES 516-325-SA72
PX	PX-Number		47158_00
TECH	Tech. Details		<a href="#">Tech. Details</a>
L1	L1		0.0 Zoll
ICON	ICON		 47158_00.bmp



















## Product selection with product selector.

The selection can be even more simplified, if the customer immediately goes to “special properties“ and selects „pressure rated up to 20 bars,“. The desired result appears with only one click.

 Please select the desired product according to technical criteria. Selectable attributes are highlighted with the table icon. Selections can be reset by clicking on the table icon or on the value.

Available products: 1  Remove all filters

Name	Description		Value
BA	Series		M12
AN	Connection		Connector
SAU	Switching output		PNP
SEL	Snap switches function		normally-open
EIN	Mounting		flush
BSA	Rated operating distance		2,00 mm
WG	Housing material		CuZn
BG	Housing Size		M12x1x31,0 mm
BE	Special properties		Pressure-rated up to 20 bar
HN	Trade name		
BC	Order code		BES0451
AB	Product identifier		BES 516-325-SA72
PX	PX-Number		47158_00
TECH	Tech. Details		<a href="#">Tech. Details</a>
L1	L1		0.0 Zoll
ICON	ICON		 47158_00.bmp

Search text:

CAD model 3D preview

Actions

This is a pregenerated default preview. It may differ from your current selection.

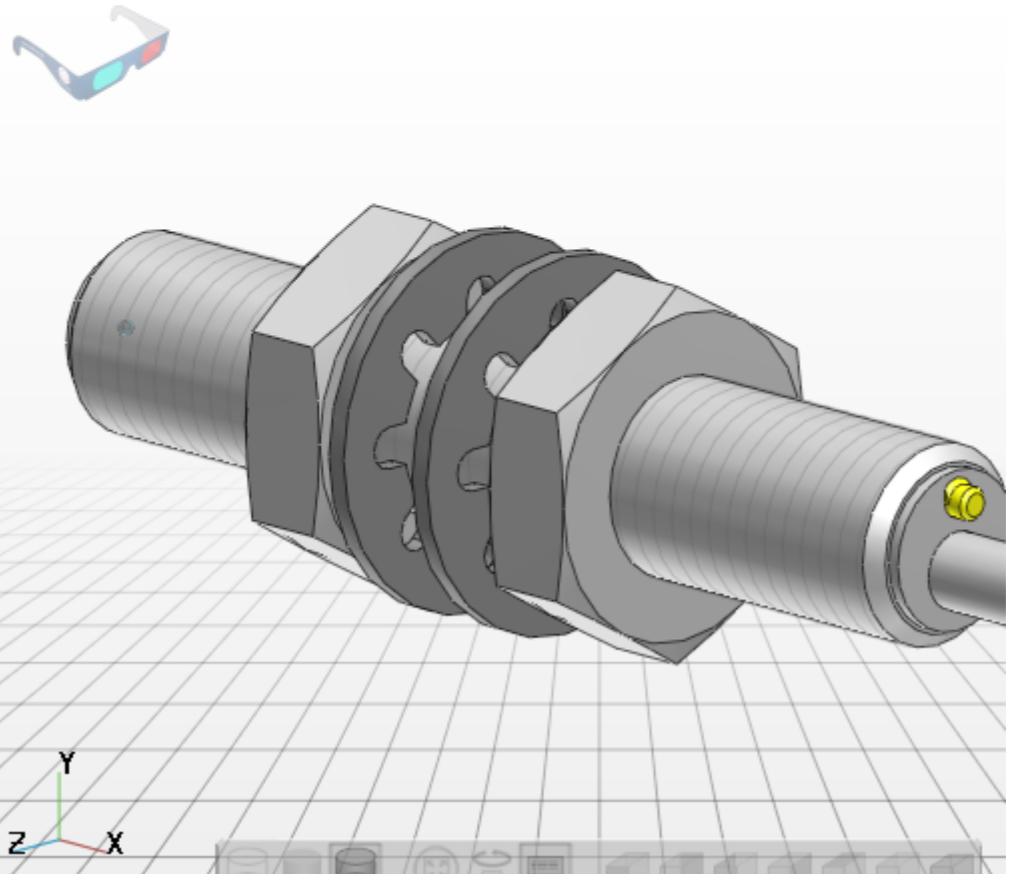





## Product selection with product selector.

On the Balluff website we placed direct links to the 3D catalog detail pages and to the product preview of the PARTcommunity catalog.

The screenshot shows the Balluff website interface. At the top right, there are navigation options for "Balluff weltweit" and language selection "Deutsch | English". Below this is a search bar and a row of navigation icons. The main navigation menu includes "Home", "Aktuelles", "Produkte", "Service", "Unternehmen", and "Kontakt". A secondary menu shows "Produkt-Detail", "Produkt-Downloads", and "Produkt-Zubehör". The main content area is titled "Induktiver Sensor" with a product image of a cylindrical sensor. Below the image is a red-bordered box containing a "360°" rotation icon and a "3D" icon. To the right of the image, the product code "Bestellcode: BES0451" and "BES 516-325-SA72" is displayed. A table of "Schlüsselmerkmale" (Key features) and "Allgemeine Merkmale" (General features) is provided. On the right side of the page, there is a "Quicklinks" section with links for "Zurück zur Auswahl", "Zurück zum Produktbereich", and "Ähnliche Produkte".

**BALLUFF**  
sensors worldwide

Balluff weltweit Deutsch | English

Home Aktuelles Produkte Service Unternehmen Kontakt

Produkt-Detail Produkt-Downloads Produkt-Zubehör

produkte

**Induktiver Sensor**

Abbildung ähnlich

Bestellcode: BES0451  
BES 516-325-SA72

**Schlüsselmerkmale**

Baugröße	M12
Anschluss	Steckverbinder, M12x1-S04
Schaltausgang/Schaltfunktion	PNP/Schließer (NO)
Betriebsspannung	10...30 V DC
Besondere Eigenschaften	druckfest
Mechanische Einbaubedingung	bündig
Bemessungsschaltabstand Sn	2 mm

**Allgemeine Merkmale**

Bereitschaftsverzug tv max.	10 ms
Gebrauchskategorie	DC 13
Schaltfrequenz f max.	1000 Hz
Temp.-Drift max. (% von Sr)	10%

**Quicklinks**

- Zurück zur Auswahl
- Zurück zum Produktbereich
- Ähnliche Produkte



# Balluff Catalog on PARTcommunity with product selectors

The product selector is compact, clearly arranged and intuitively comprehensible.

These selectors are also flexible and easy to maintain for the person who is responsible for the catalog.

Since there are Excel tables in the background, it is possible to move the columns with selection properties back and fourth at any time, add further selection criteria and even automate the results.



BALLUFF BIS C-130-05/L-SA1

Available products: 21

Remove all filters

Name	Description		Value
VF	Verfügbarkeit		Available
BAU	Series		BIS C (LF, 70 kHz)
BG	Housing Size		Ø15,5x7,00 mm

The product selector brings a new fourth dimension in the 3D catalog.





# Balluff Catalog on PARTcommunity with product selectors

**BALLUFF**  
sensors worldwide



This way we continue our success story.



**CADENAS**  
**SETTING STANDARDS**